

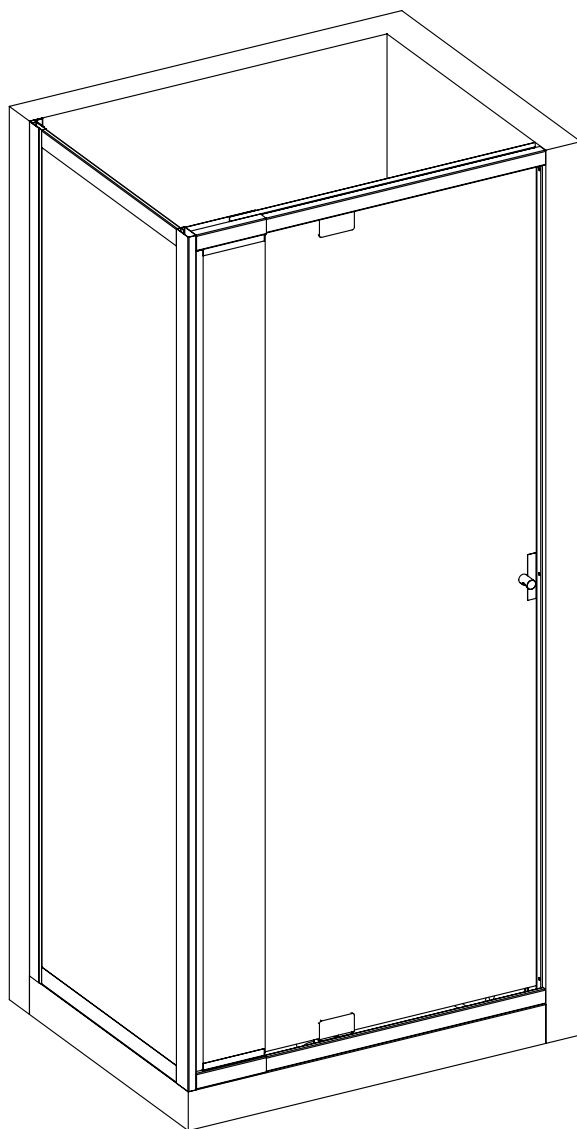

BIANCHI & FONTANA

PALMA PP



MATERIALE CONTENUTO ALL'INTERNO DELL'IMBALLO COMPOSTO DA 1 SCATOLE:

1. PARETE LATERALE FISSA

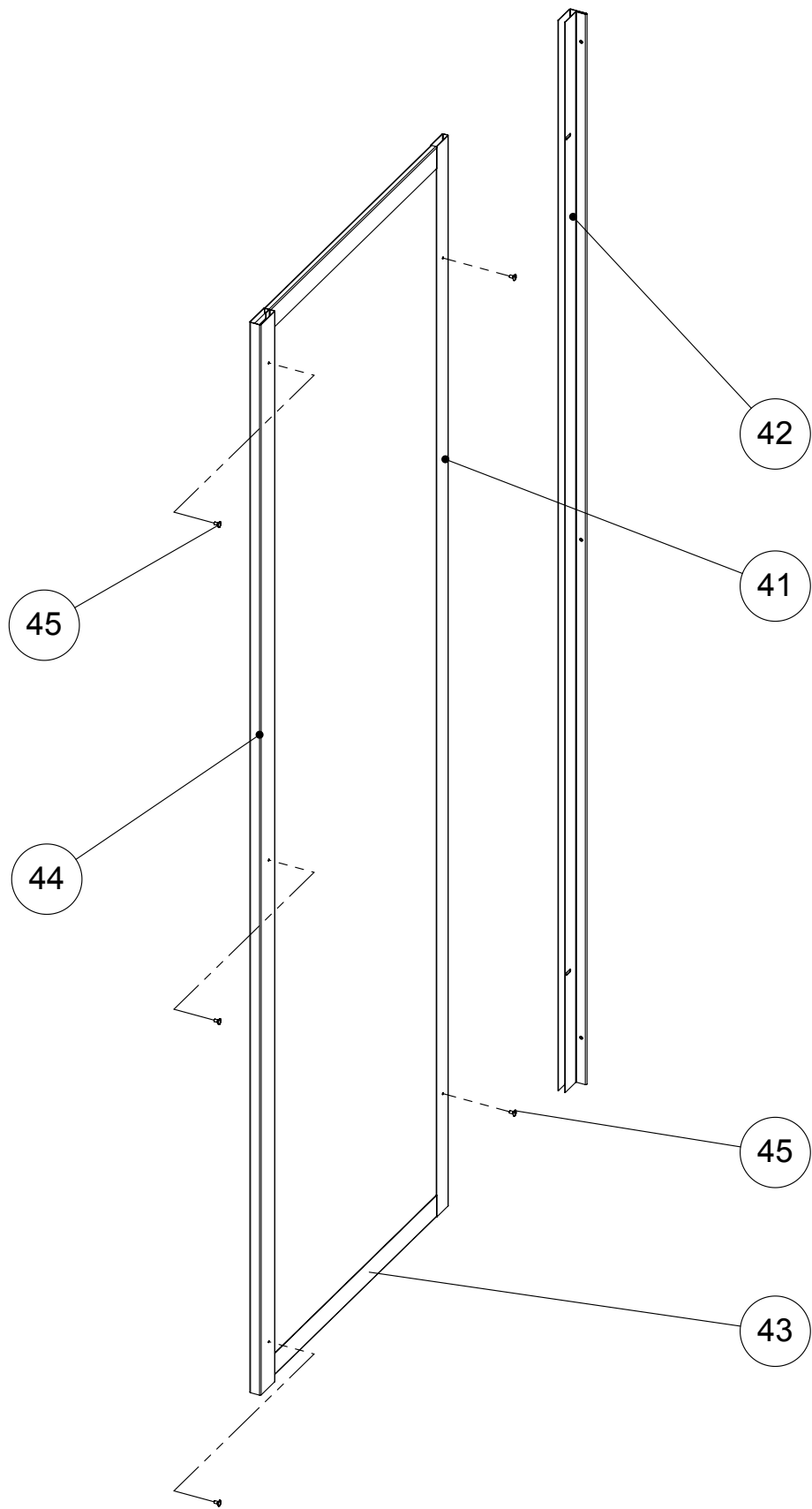

FASE 10

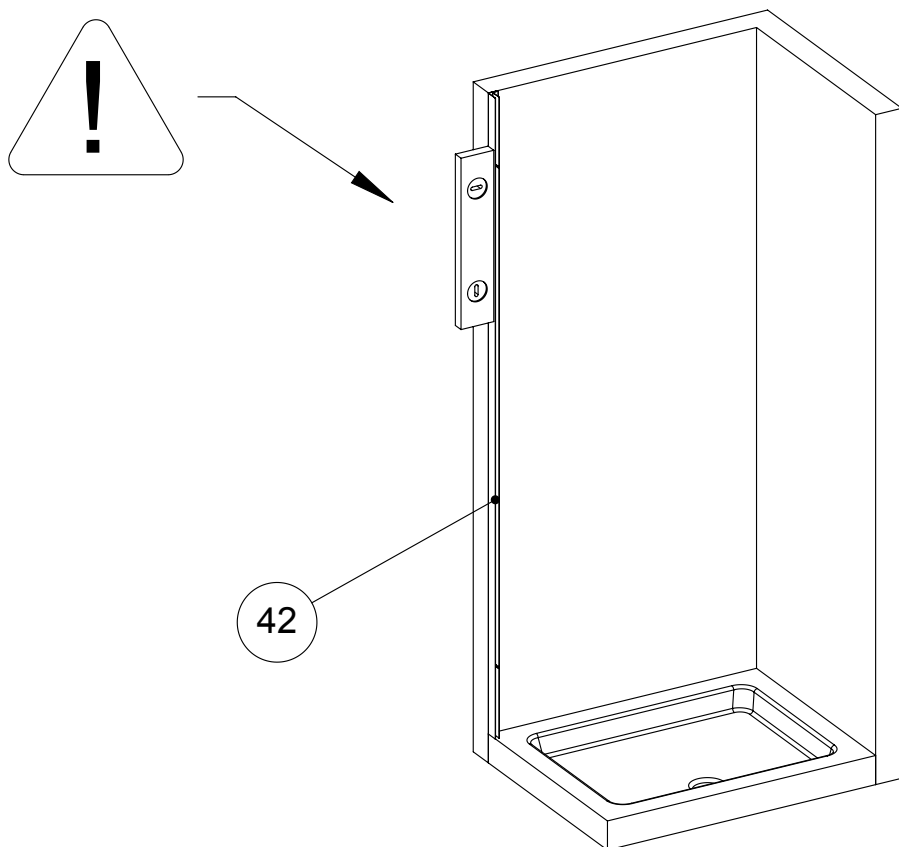

- (A) TOGLIERE LA PELLICOLA PROTETTIVA DAL PROFILO (42) PRIMA DEL MONTAGGIO
- (B) METTERE A PIOMBO IL PROFILO (42) E UTILIZZARLO PER TRACCIARE LE FORATURE DI FISSAGGIO ALLA PARETE
- (C) ESEGUIRE I FORI PER I TASSELLI
- (D) INSERIRE I TASSELLI
- (E) FISSARE IL PROFILO DI COMPENSAZIONE (42) A MURO TRAMITE LE VITI CON TASSELLI ACCERTANDO CHE IL COMPENSATORE SIA PERFETTAMENTE A PIOMBO

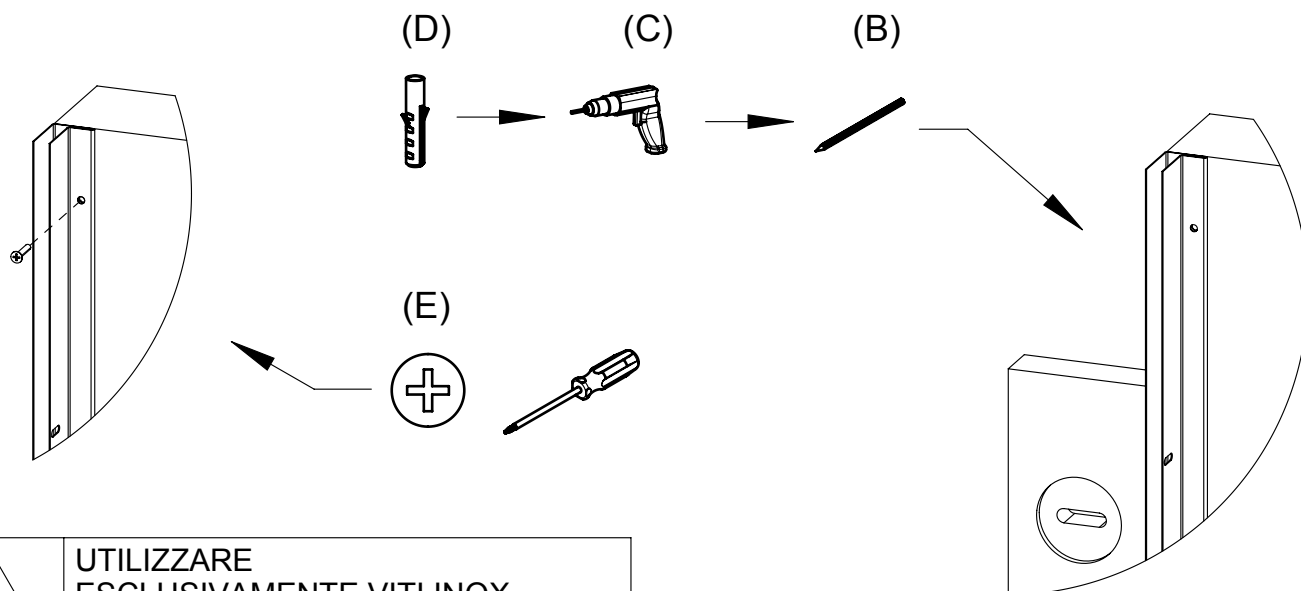

UTILIZZARE
ESCLUSIVAMENTE VITI INOX
il non utilizzo di viti inox può trasmettere
la presenza di ruggine nella struttura

FASE 20

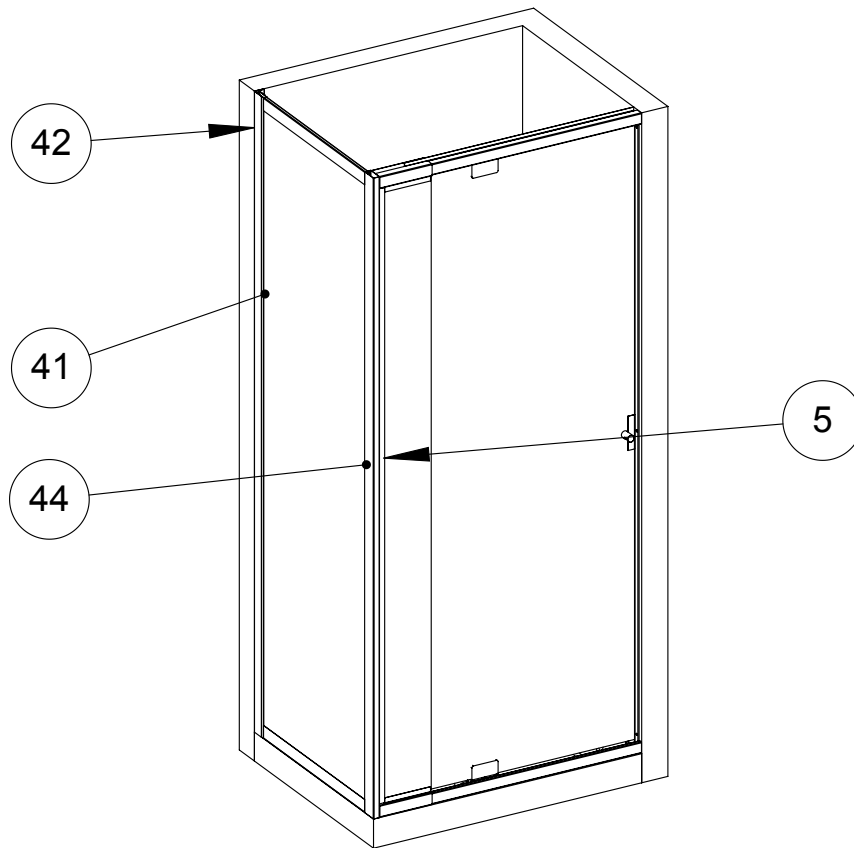

- (A) TOGLIERE LA PELLICOLA PROTETTIVA DAI RIMANENTI PROFILI DELLA PARETE LATERALE
- (B) INSERIRE IL PROFILO (41) NEL PROFILO (42)
- (C) FISSARE IL PROFILO (44) CON IL PROFILO COMPENSATORE (5) DEL BOX OASI CON LE VITI (45) IN DOTAZIONE

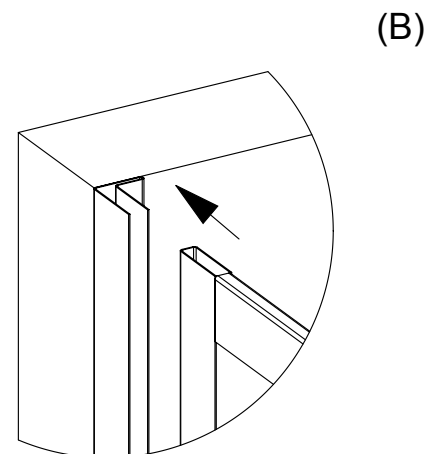
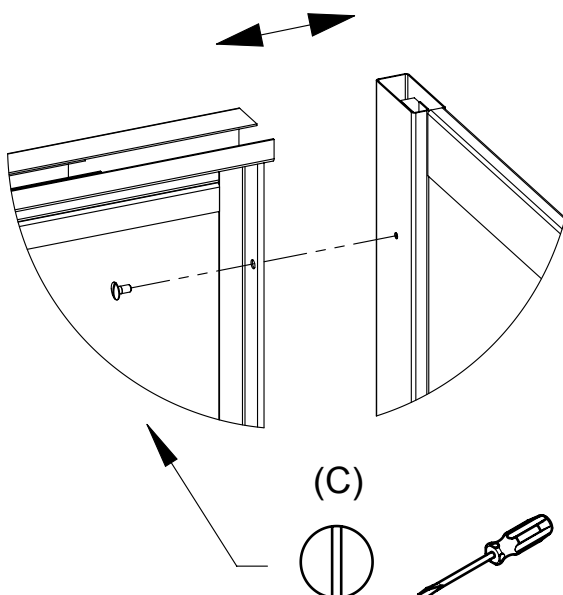

FASE 30

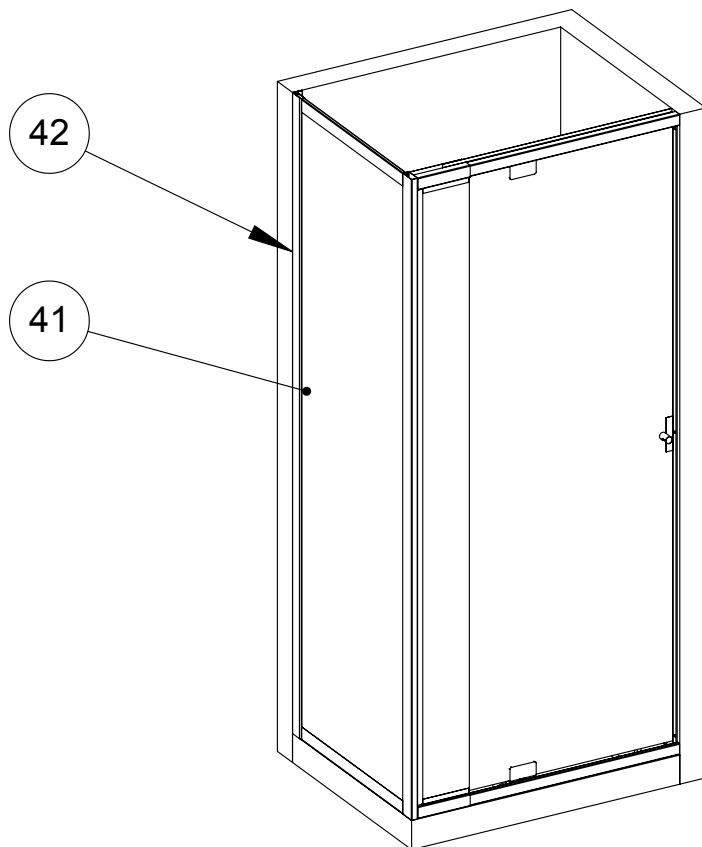

(A) FISSARE I PROFILI (41) E (42) CON LE VITI (45)

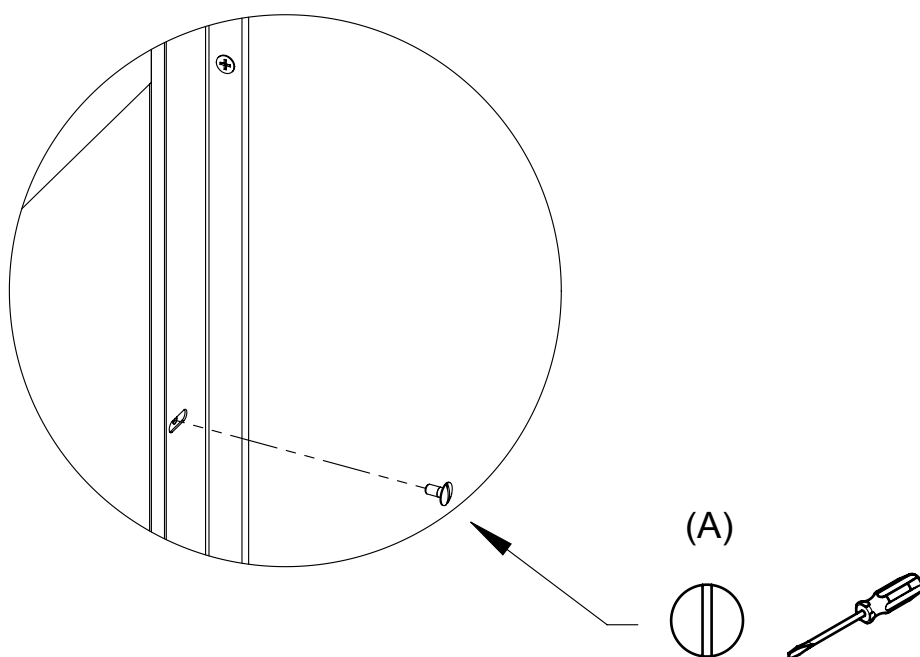

FASE 40

(A) SILICONARE NEL LATO ESTERNO IL PROFILO (43)

(A)

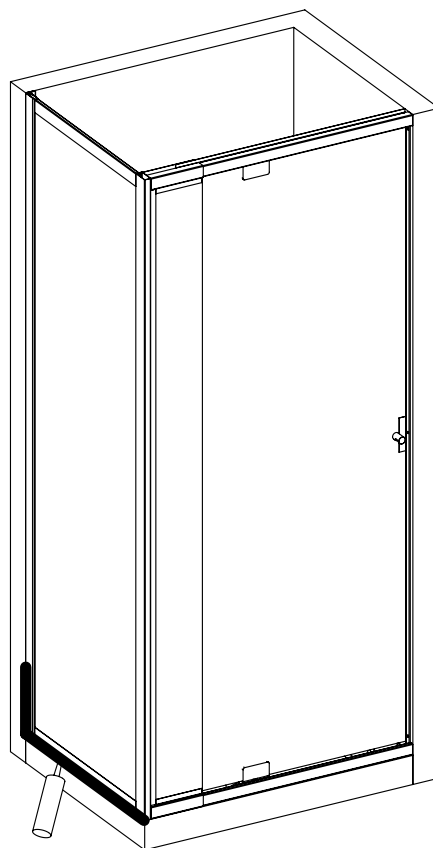
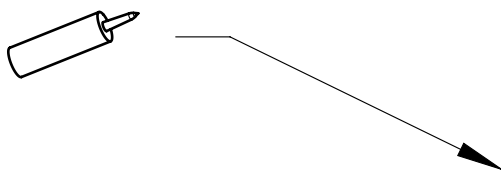

(B) SILICONARE NEL LATO INTERNO IL PROFILO (42)

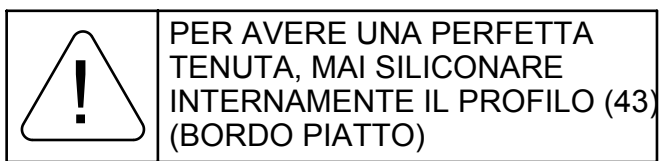

(B)

